

Product information RA 602

stationary suction systems for dusts

- » suction system suitable for continuous operation thanks to efficient filter cleaning
- » filter units can be decoupled so that the full power is temporarily available on one filter tower
- » 2 x 100 litre collection tanks, run-out
- » maintenance-free side channel compressor suitable for multiple shift operation

Features



Bag filter with electric shaker

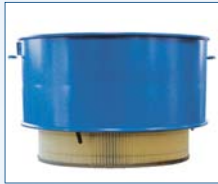

Absolute filter element for microfine dusts (filter class "H")



ultrasonic distance sensor for level monitoring

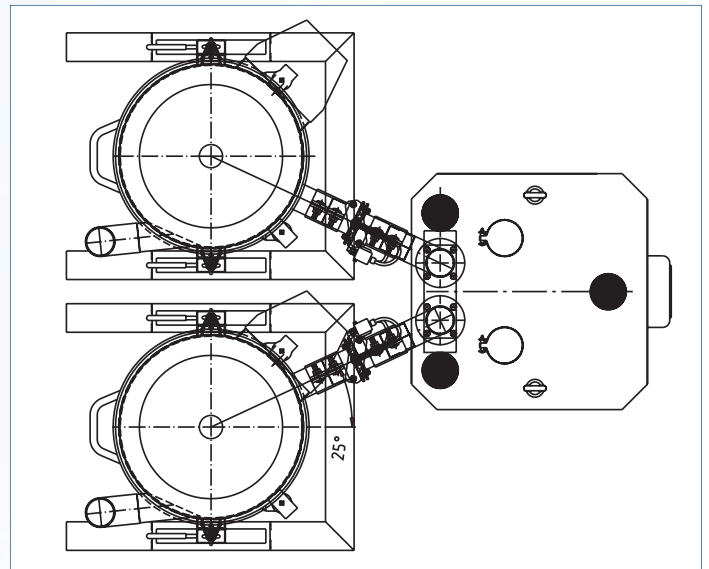

RA 602

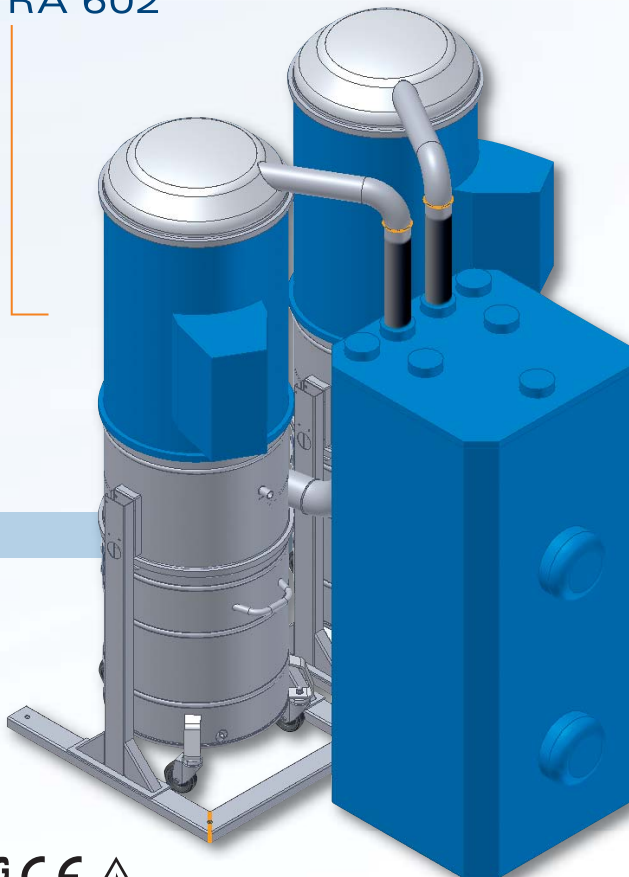

Central suction system with two-way filter cleaning for suction extraction in multiple shift operation

For the suction extraction of all kinds of process dusts, connected by Ringler piping systems and to machining centres.

Technical data for the series RA 602

Suction unit type	RA 602 D2x5,5
Output [kW]	11,0
Voltage [V]	400
Max. vacuum [kPa]	26
Max. air flow rate [Nm ³ /h]	1.040
Sound level dB [A]	74
Dimensions [mm]	1.692 x 1.448 x 2.012
Weight [kg]	498
Article number	990 0348

