

Product information RE 402

dust collection units with bag filter

- » suitable for the suction extraction of dusts, chips and liquids, chips also over longer distances, various filter qualities available
 - » optional: various discharge systems such as cellular wheel sluice, double chamber discharge, Big Bag, etc.
- > **further info on page 71**



RE 301 with spindle extraction nozzle on a Boehringer portal milling centre

RE 402

Features

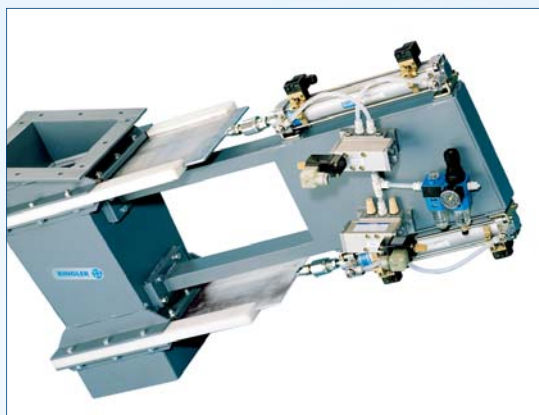

Disposal with twin gate discharge



Technical data for the series RI 402

Suction unit type	RE 402 D2x11
Output [kW]	22,0
Voltage [V]	400
Max. vacuum [kPa]	7
Max. vacuum [Nm ³ /h]	7.000
Sound level dB [A]	75
Dimensions [mm] - approx.	1.900 x 1.000 x 5.000
Weight [kg] - approx.	1.500
Article number	990 0975

