

Product information RI 321

## mobile chips and coolant suction devices

- » drive unit remains on the running gear when the tank is extended
- » d.c. and a.c. drives
- » can be used as an industrial suction unit or stationary unit on cutting machines



RI 321 D3: used here for the automatic extraction of oil on pallet deck spacers in the automotive industry

Features



100l run-out collection tank



Optional: Emptying by tipping with frame as emptying aid



Optional: Crane transport by means of crane bow

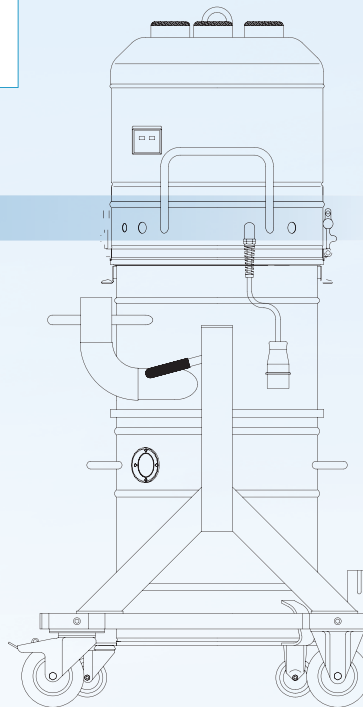

RI 321



Fig.: d.c. model 400V

Technical data for the series RI 321

Suction unit type	RI 321 W2 G	RI 321 W2 E	RI 321 D1,5	RI 321 D3	RI 321 D4
Output [kW]	2,0	2,6	1,5	3,0	4,0
Voltage [V]	230	230	400	400	400
Max. vacuum [kPa]	22	23	21	32	26
Max. air flow rate [Nm³/h]	360	430	210	320	520
Sound level dB [A]	75	76	56	60	62
Dimensions [mm]	745 x 710 x 1.420	745 x 710 x 1.420	850 x 760 x 1.800	850 x 760 x 1.800	850 x 760 x 1.920
Weight [kg]	88	89	124	136	155
Article number	990 0139	990 0919	990 0141	990 0215	990 0304

